

指示がない限り、穴加工部分の寸法に對する寸法許容差	0.5以上 6以下	±0.05
区分	6を越え 30以下	±0.1
	120を越え 400以下	±0.15
	120を越え 1000以下	±0.2
	400を越え 1000以下	±0.3

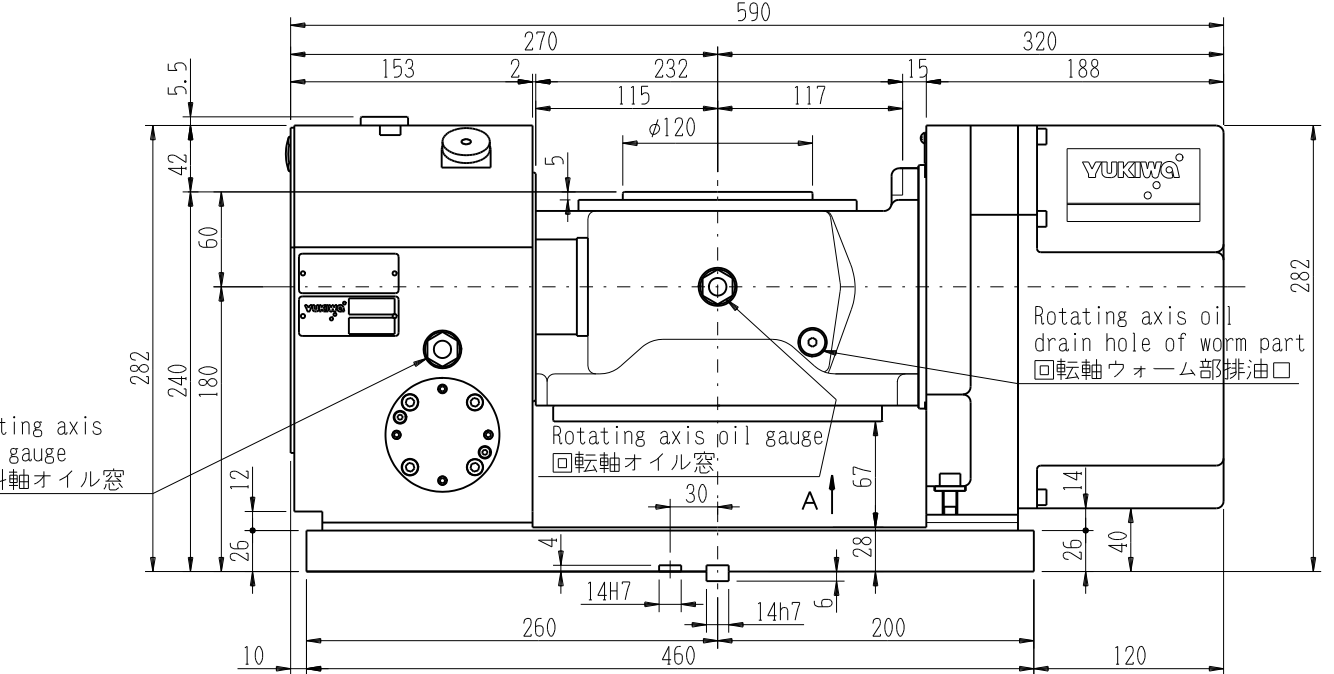

	Rotating axis 回転軸	Tilting axis 傾斜軸
AC servo motor ACサーボモータ	AC5/AC4-30 SANYO P50B08075HXS70 BC1-30 YASKAWA SGMH-08A1A6S BTC37 YASKAWA SGMH-08A4A6S BTC39 YASKAWA SGMH-08A4A6S AC5-30A SANYO R2AA08075FXPGME6	SANYO P50B08075HXS70 YASKAWA SGMH-08A1A6S YASKAWA SGMH-08A4A6S YASKAWA SGMH-08A4A6S SANYO R2AA08075FXPGME6
Total reduction ratio 総合減速比	1/72	1/120
Max. number of revolutions テーブル最高回転数	41.6min <sup>-1</sup> (τ- $\phi 3000$ min <sup>-1</sup> )	25min <sup>-1</sup> (τ- $\phi 3000$ min <sup>-1</sup> )

For table clamping, connect air at a pressure of 0.3 to 0.5 MPa through a filter 40  $\mu$ m or less.  
クランプ用エアは、40 $\mu$ m以下のフィルタを通した0.3~0.5MPaのエアを接続してください。

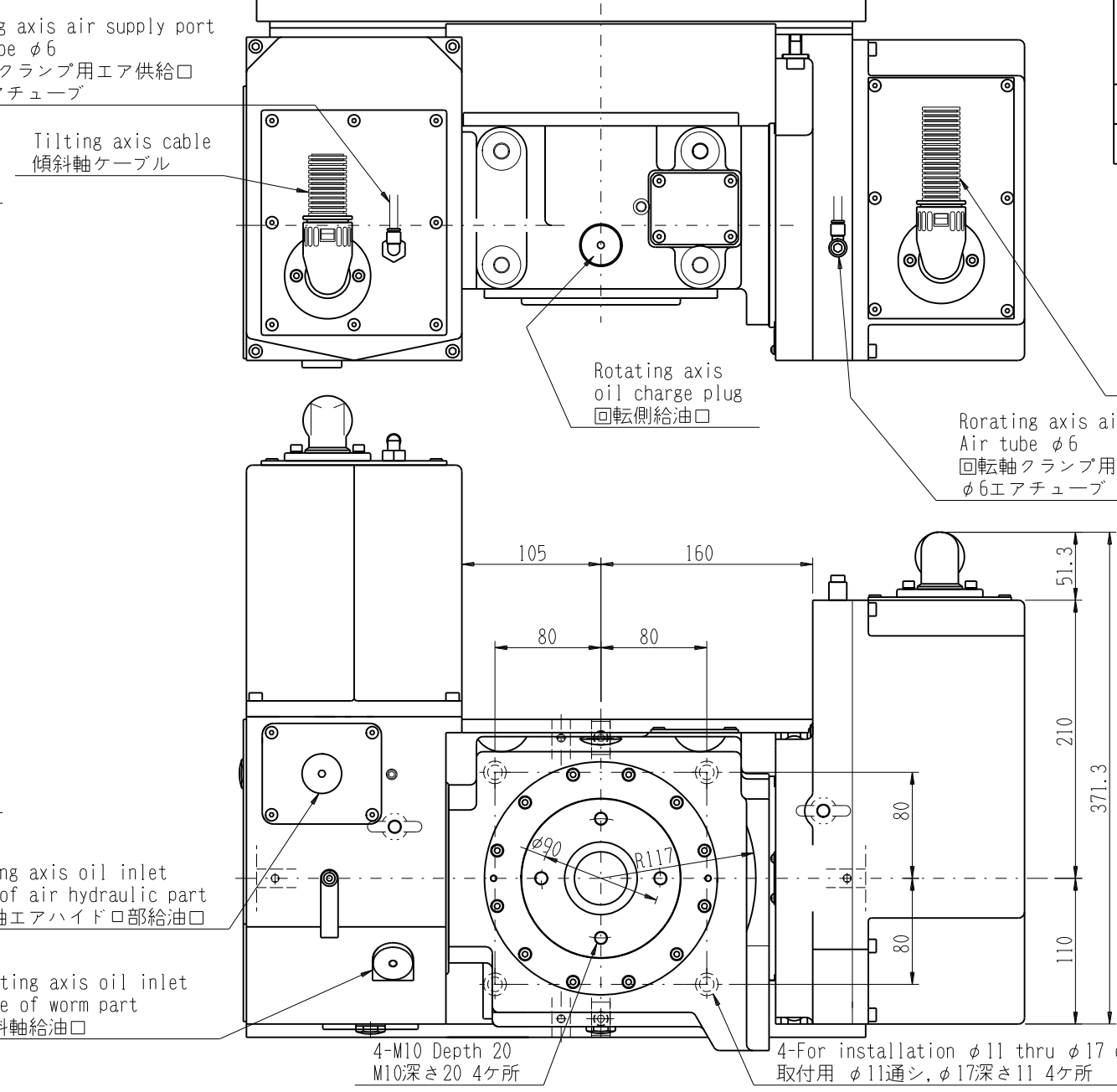
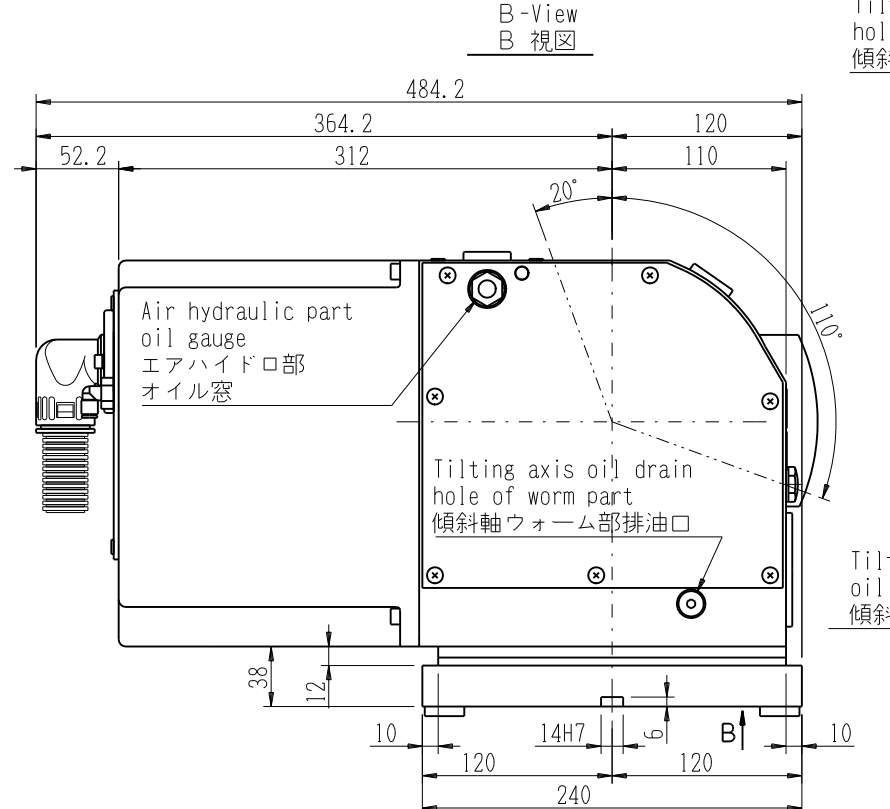
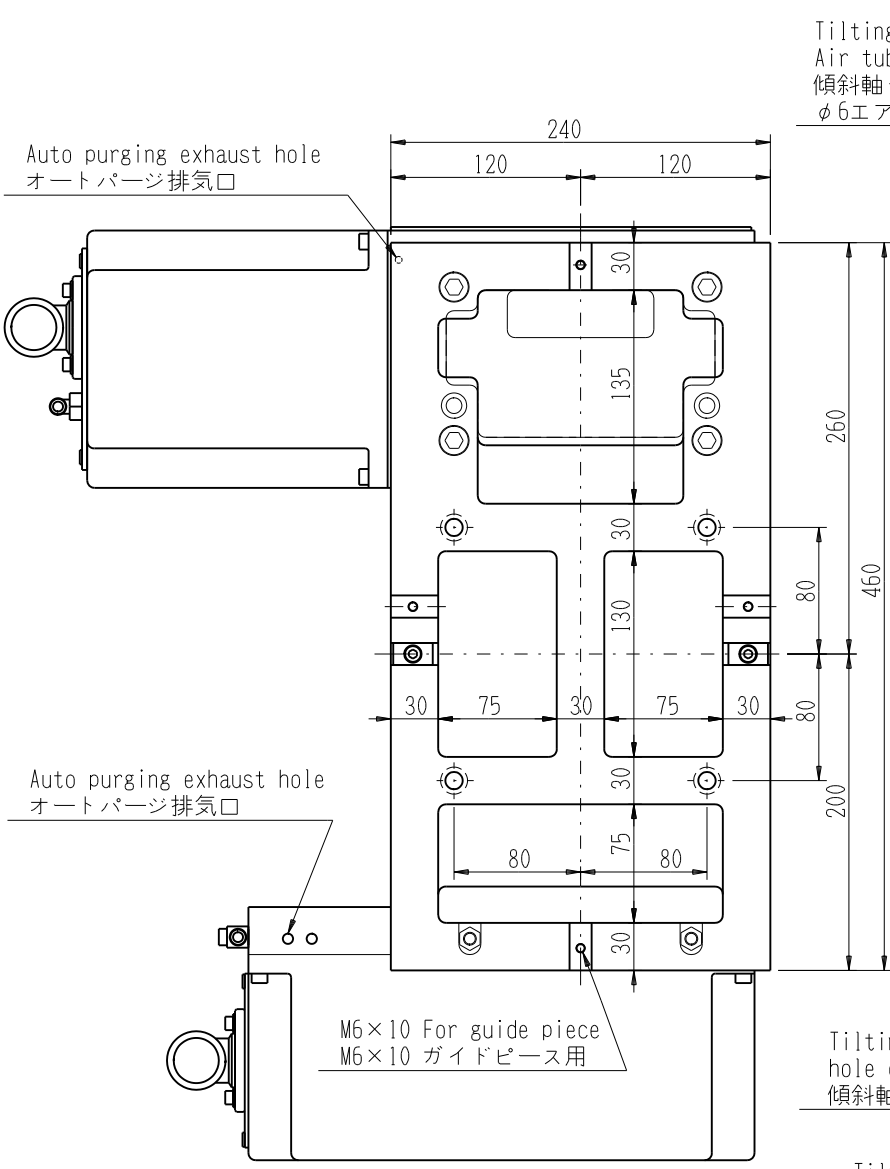
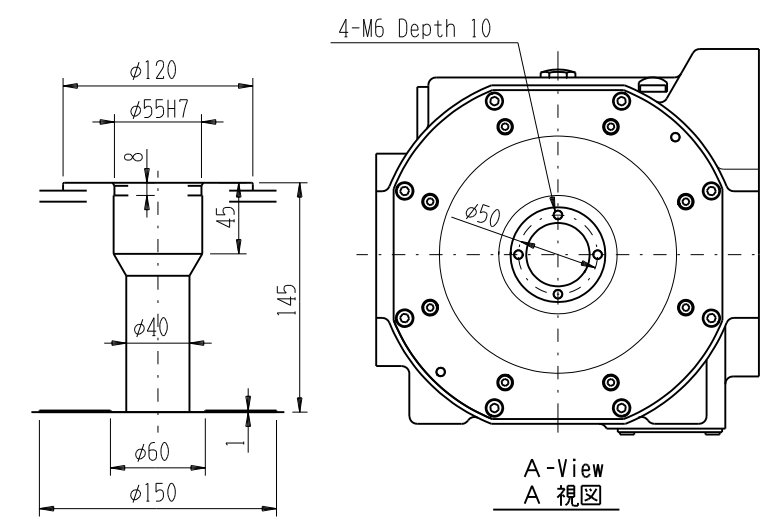
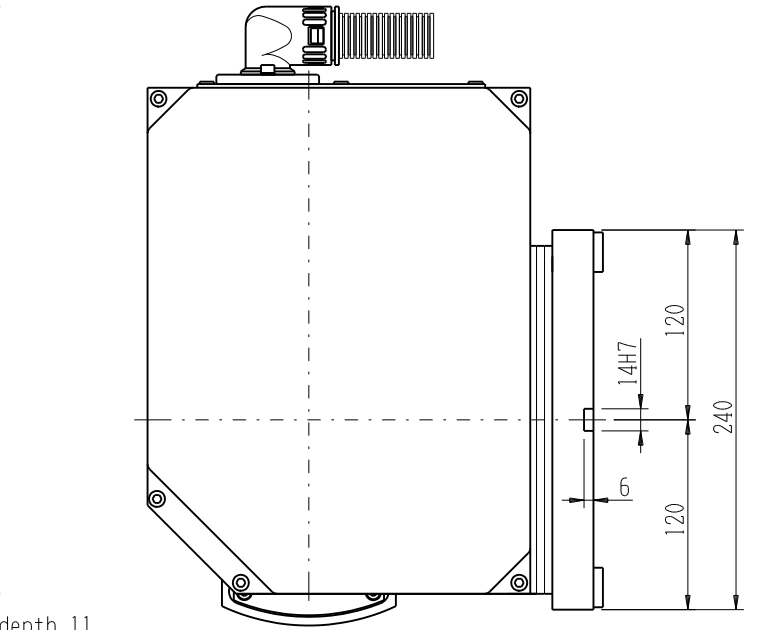

HEAT TREAT (熱処理)	APPROVED (承認)	CHECKED (審査)	DRAWN (製図)	PRODUCT NAME (製品名)	PART NAME (部品名)	MATERIAL (材質)	SCALE (尺度)
			21.1.7 小川	CNC TILTING ROTARY TABLE CNC 傾斜円テーブル TNT170R AC5-30/30A, AC4-30, BC1-30 BTC37/39	Outside drawing 外観図		1/5
REVISION	DATE	NAME	YUKIWA SEIKO INC.		DWG. No. (図番)		TNT170R-D01-K6

±0.3	400 以下	1000 以下
±0.2	120 以下	400 以下
±0.15	30 以下	120 以下
±0.1	6 以下	30 以下
±0.05	0.5 以上	6 以下
許容差		
指示がない限り、穴加工部分の寸法に對する寸法許容差		

AC servo motor ACサーボモータ	Rotating axis 回転軸 AC5/AC4-30 SANYO P50B08075HXS70 BC1-30 YASKAWA SGMAH-08A1A6S BTC37 YASKAWA SGMAH-08A4A6S BTC39 YASKAWA SGMAH-08A4A6S AC5-30A	Tilting axis 傾斜軸 SANYO P50B08075HXS70 YASKAWA SGMAH-08A1A6S YASKAWA SGMAH-08A4A6S SANYO R2AA08075FXPGME6 SANYO R2AA08075FXPGME6
Total reduction ratio 総合減速比	1/72	1/120
Max. number of revolutions テーブル最高回転数	41.6min <sup>-1</sup> (ε-93000min <sup>-1</sup> )	25min <sup>-1</sup> (ε-93000min <sup>-1</sup> )

For table clamping, connect air at a pressure of 0.3 to 0.5 MPa through a filter 40 μm or less.  
クランプ用エアは、40μm以下のフィルタを通した0.3~0.5MPaのエアを接続してください。

Rotating axis cable  
回転軸ケーブル

Rotating axis air supply port  
Air tube φ6  
回転軸クランプ用エア供給口  
φ6エアチューブ

Rotating axis oil charge plug  
回転側給油口

Tilting axis air supply port  
Air tube φ6  
傾斜軸クランプ用エア供給口  
φ6エアチューブ

Tilting axis cable  
傾斜軸ケーブル

Auto purging exhaust hole  
オートバージ排気口

Auto purging exhaust hole  
オートバージ排気口

Tilting axis oil inlet hole of air hydraulic part  
傾斜軸エアハイドロ部給油口

Tilting axis oil inlet hole of worm part  
傾斜軸給油口

M6×10 For guide piece  
M6×10 ガイドピース用

B-View  
B 視図

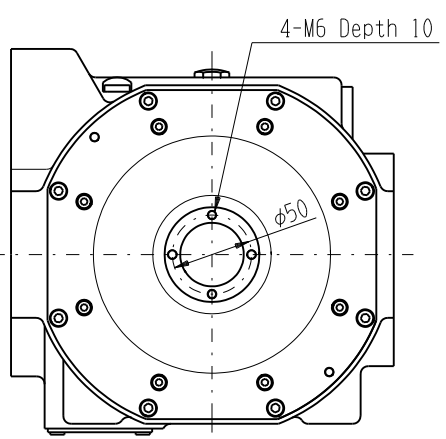
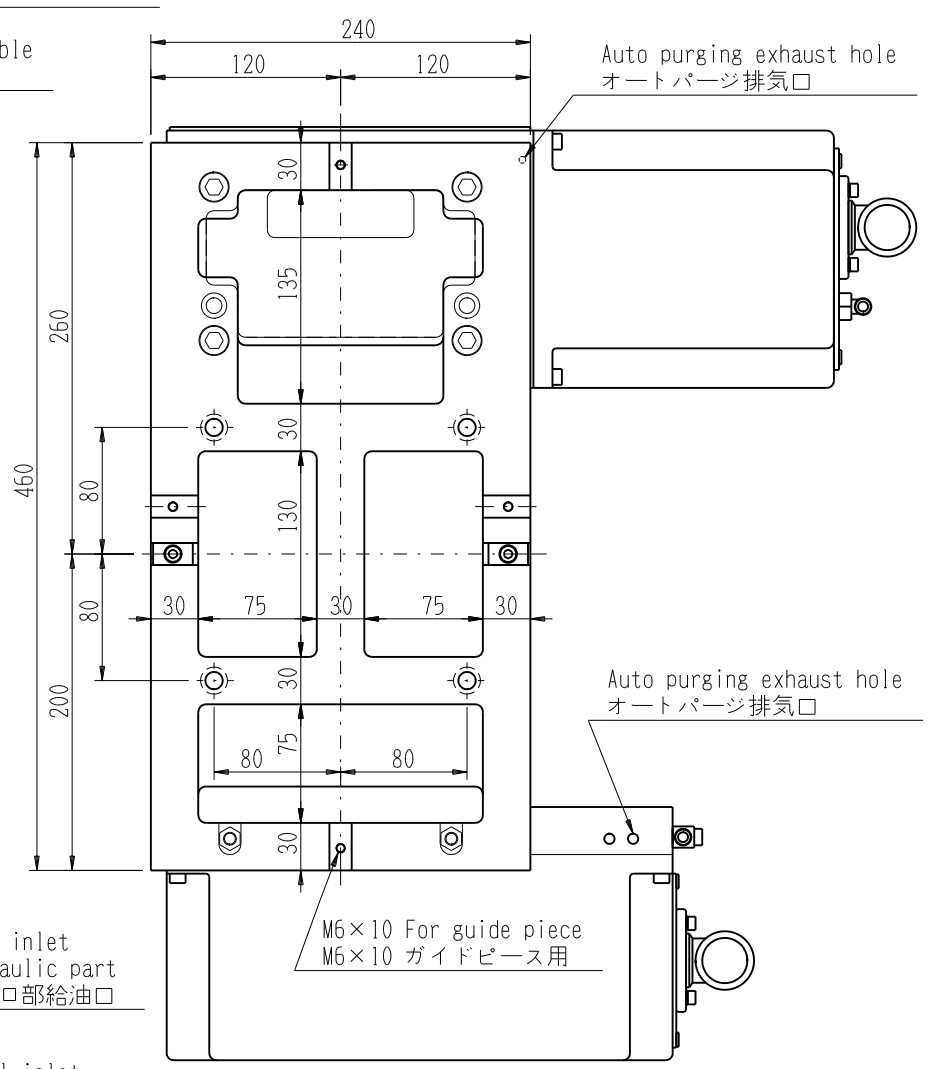
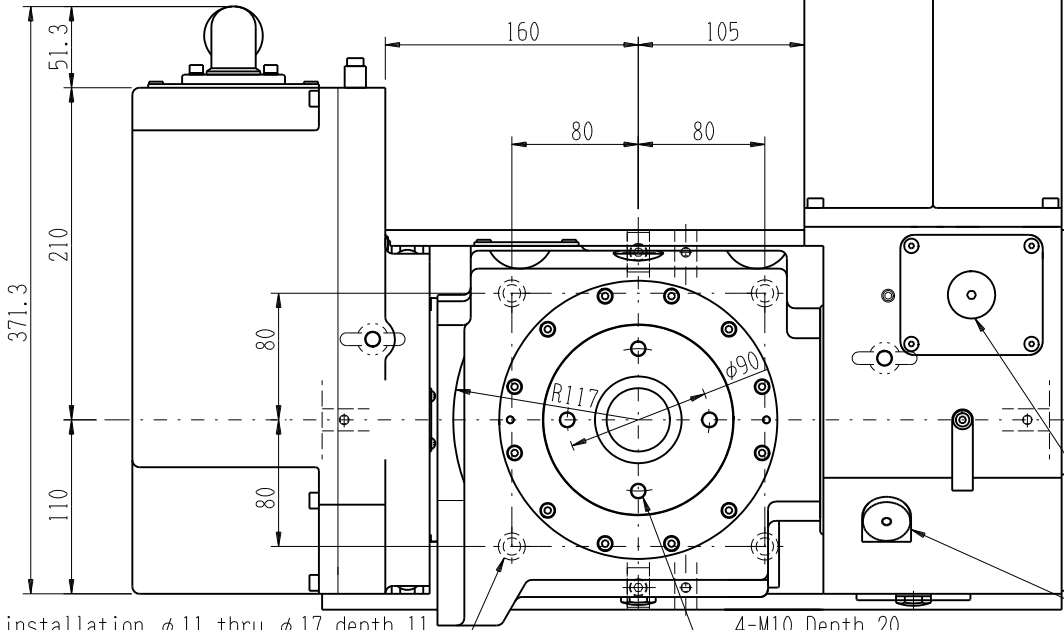
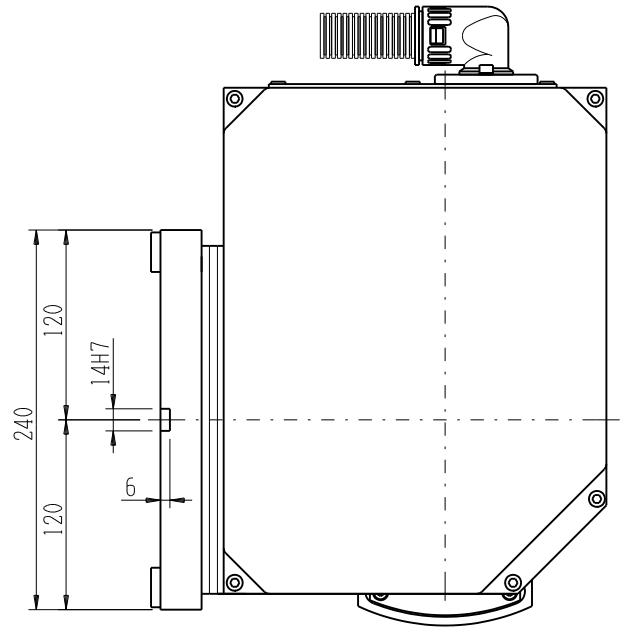

A-View  
A 視図

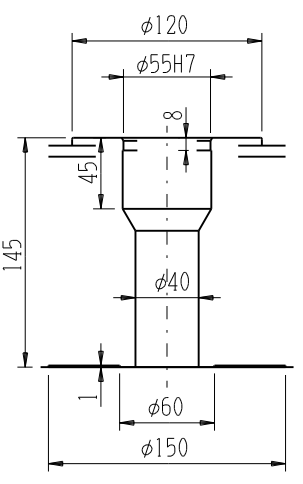
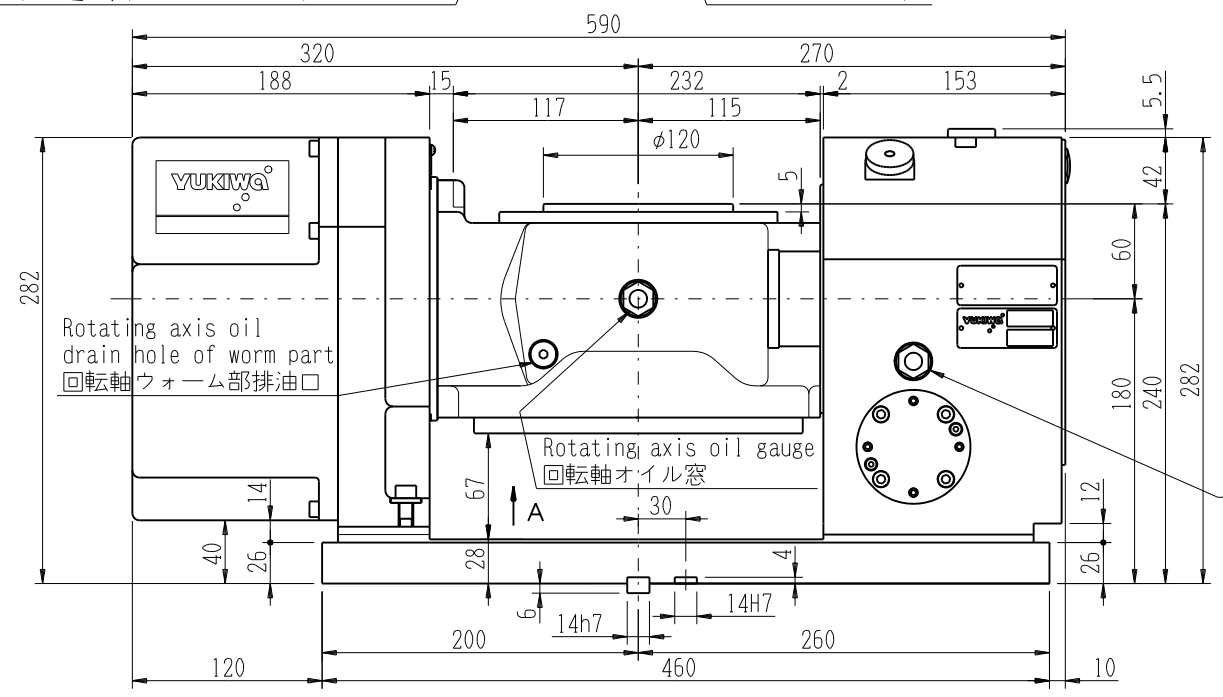

Table thru-hole  
テーブル貫通穴



Rotating axis oil drain hole of worm part  
回転軸ウォーム部排油口

Rotating axis oil gauge  
回転軸オイル窓

Tilting axis oil gauge  
傾斜軸オイル窓

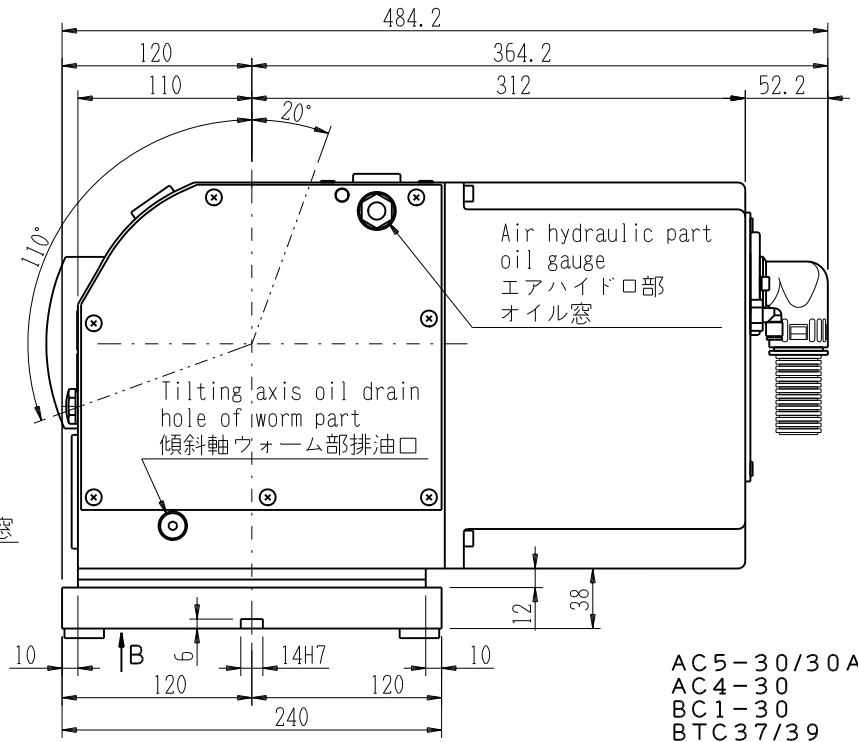

Air hydraulic part oil gauge  
エアハイドロ部  
オイル窓

Tilting axis oil drain hole of worm part  
傾斜軸ウォーム部排油口

AC5-30/30A  
AC4-30  
BC1-30  
BTC37/39

REVISION	DATE	NAME	HEAT TREAT (熱処理) APPROVED (承認) CHECKED (審査) DRAWN (製図) 21.1.7 小川	PRODUCT NAME (製品名) CNC TILTING ROTARY TABLE CNC 傾斜円テーブル TNT170L AC5-30/30A, AC4-30, BC1-30 BTC37/39	PART NAME (部品名) Outside drawing 外観図	MATERIAL (材質)	SCALE (尺度) 1/5	DWG. No. (図番) TNT170L-D01-K8
YUKIWA SEIKO INC.								